

SpeedHone

essential/compact/flexible

Compact, electronically controlled horizontal honing machine that is ideal for one-off and batch production work.



SpeedHone

essential/compact/flexible

Welcome to the delapena group

delapena group are leading honing specialists in the UK and around the world.

We design and manufacture a wide range of standard and bespoke honing machines, tooling and abrasives for the Automotive, Aerospace and other manufacturing sectors.

Our services include application development, bespoke tooling design, process engineering, tooling refurbishment, maintenance, consultancy and training.



Contents

Page 3 - Introducing the SpeedHone

Page 4 - Features & benefits

Page 5 - Floor plan

Page 6 - Technical specifications

Page 7 - Your complete honing supplier - Tooling

Page 8 - Your complete honing supplier - Services

Page 9 - The wider range

Page 10 - iHone technology

Introducing the SpeedHone

essential/compact/flexible

delapena is a global leader in honing technology, with over 95 years of experience in designing and manufacturing honing machines and tooling. delapena honing machines are used by some of the world's leading companies in the automotive, aerospace, oil and gas, and pharmaceutical industries.

In toolrooms across the world you will find a delapena SpeedHone. The compact, electronically controlled horizontal honing machine that is ideal for one-off and batch production work. It is designed to de-skill the honing process, making it easy to train operatives and achieve consistent results.

Recent years the demand for intuitive programming, push button operation and the requirements of customer specific machines, has led to the design and manufacture of the new SpeedHone. With simple, easy to use operating system displayed on a HMI screen and controlled from a front facing panel; in process adjusting; short stoking and stock removal setting are at the operator`s fingertips.





Features & Benefits

The delapena SpeedHone is the perfect choice for businesses that are looking for a high-quality honing machine that can help them to improve their production efficiency and quality, and achieve the following benefits:

Benefits of using delapena honing machines:

- Improved surface finish and geometry
- Increased accuracy and repeatability
- Reduced scrap rates
- Extended tool life
- Increased productivity
- Lower production costs

Benefits of using the delapena SpeedHone honing machine:

- Fast and efficient honing
- Easy to use and operate.
- Quick tooling changes
- Accurate and repeatable results
- Ergonomic design
- Compact footprint

pioneering the way forward in honing

Floor plan

Essential
Compact
Flexible

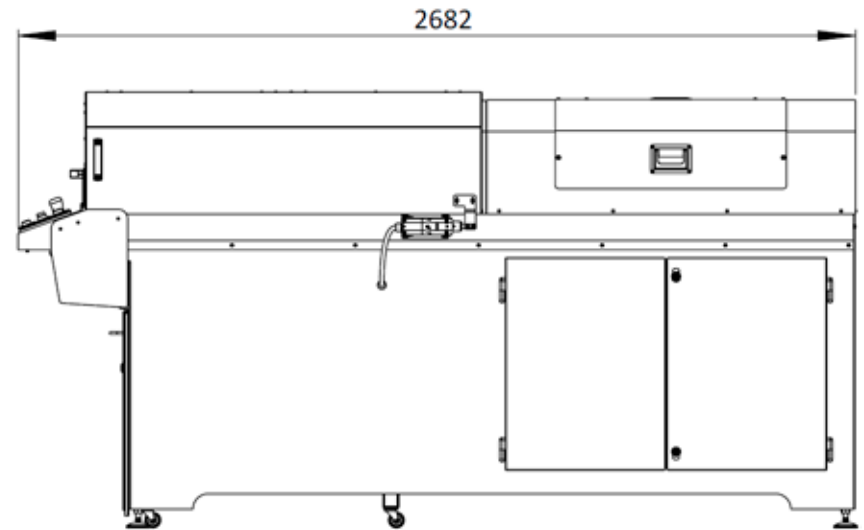
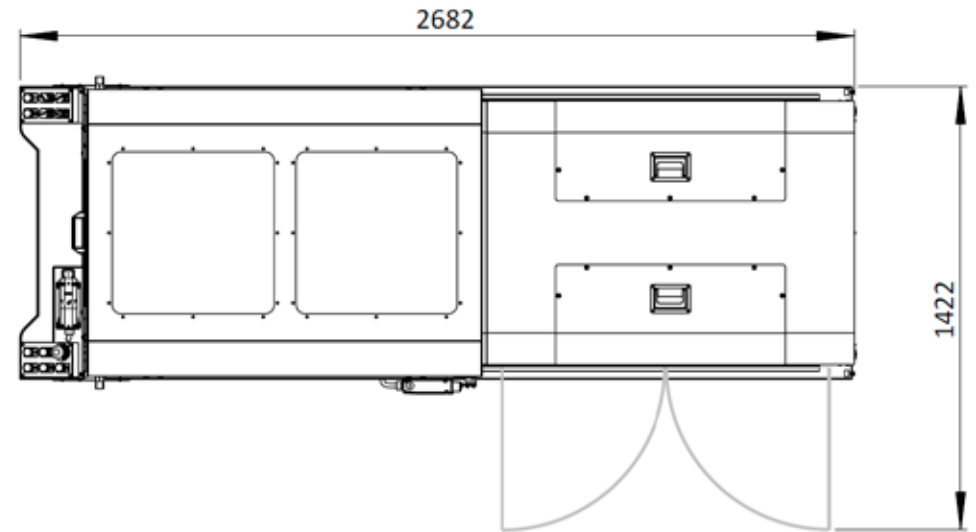
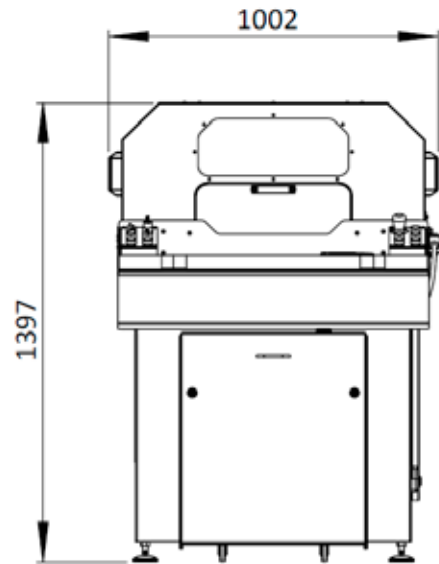

Technical specifications

Capacity

Diameter range - 1.14 - 80mm

Maximum reciprocation length - 250mm

Motors

Rotation system
Spindle speed: Infinitely variable
within range of 250 to 2500 rpm.

Rotation motor:
1.5kW – 6 pole AC motor.

Braking:
Dynamic Braking Resistor.

Spindle Control:
Variable Speed Drive.

Reciprocation system

Stroking motor:
0.90kW Synchronous AC servomotor.
Stroking motion:
Belt driven, high precise anti-backlash ball screw.
Stroking speed:
1.0 – 25.0 Metres / minute - Infinitely variable.
Stroking length:
1.0 to 500mm programmable to 0.1mm increments.
Short stroking (option):
Length and frequency of short strokes fully
programmable – minimum 1.0mm both ends.

Controls

Two control panels with hard wired buttons /
switches.
Display: 4" TFT full colour display.

Expansion System

Feed Type - Programmable electro-mechanical
Feed Rate - Programmable + Timer
Feed Increment - 1 micron increments per second.

Electrical System

Conformity - UKCA/CE Approved
Voltage - 380-415V, 3 Phase, 50Hz.
Control Voltage - 24 VDC

Coolant System

Integral - 70L fluid tank with magnetic filtering

Weight

Net - 850kg approx.
Gross - 1000kg approx.

delapena

complete honing supplier

Tooling

At delapena we design, manufacture design an extensive range of standard and bespoke honing tooling and fixtures, in addition to specialist fittings for many other manufactures machines.

For every machine delapena makes a tool. Not only for special modifications on standard tooling, but for tools yet to be invented.

Our vertical tooling is throughout the world on a multitude of components and applications, with honing mandrels and horizontal tooling found in thousands of tool rooms..

The scope of our tooling capability is without limit and our expertise is matched by the quality of our service.

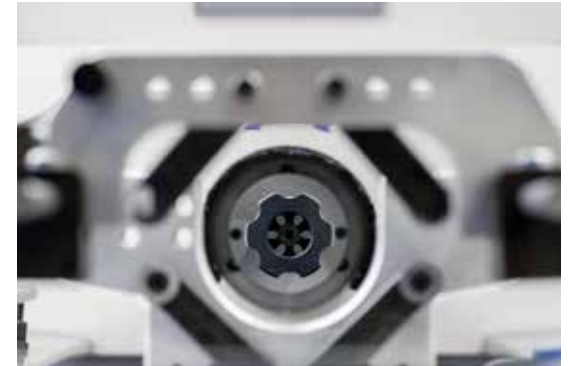
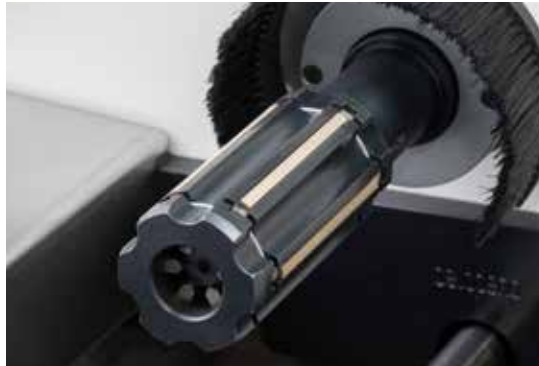

pioneering the way forward in honing

Tooling refurbishment facility

delapena offers a complete comprehensive refurbishment service for any tool, replacing abrasives, guides, and any other component of a tool in order to bring it to full working order.



Honing consultancy

Un-trained staff or inexperienced machine set up can bring your production to a stand still, resulting in a significant impact on your organisation`s productivity.

Our engineers can provide one-off troubleshooting, daily/weekly honing consultancy or training days to your honing and maintenance teams.



Machine services

To keep your components flowing at their optimal condition our engineers offer complete honing machine services.. We offer annually or fixed term service contracts.



complete honing supplier services & solutions

delapena group are experts in the honing market, readily sharing our knowledge and expertise, making us a trusted and valued partner.

Our services include bespoke tooling and machine design, reverse engineering of existing tooling as well as application development, abrasive development, honing consultancy, training, machine servicing and much more.

The wider range

Selection of new generation honing machines

Our range of honing machines are user-friendly and versatile, producing consistently high-quality results. delapena honing machines feature control systems that allow for easy setup and storage of programs, with our iHone software making this easier than ever before on our range of new flagship machines.

delapena honing machines can be found in businesses all over the world. We provide comprehensive support, training, and guidance throughout commissioning and beyond.



PowerHone E precise/efficient/versatile

The PowerHone E is a vertical honing machine for large and heavy components in small to medium batches and prototypes. Designed for both through and blind bores, producing an excellent surface finish



TubeHone dynamic/commanding/dominant

The TubeHone is the ideal machine for cylinders up to 4m in length. Our standard TubeHone hones up to 650mm bores, with bespoke options up to 1m. Powerful motors and a belt drive system ensure rapid stock removal.



PrecisionHone flagship/advanced/accurate

Our flagship machine, the PrecisionHone is a vertical honing machine for production honing of small parts. Accurate and packed with features, for large batch work and tight tolerances the PrecisionHone is the machine of choice. Now featuring our iHone technology; enabling ease of use and fast set up.



intelligent honing

delapena brings you iHone, a graphical icon based machine interface designed to simplify the process of programming our honing machines. Using Siemens` touchscreen technology we now offer a conversational style interface that is easy to use, but still packed with features.

Much our our honing knowledge and best practices are baked into the iHone system, included are on-screen help pages enabling the operator to diagnose geometry and finish issues on the machine. The controller allows for extensive program storage enabling fast setup of repeat work maximising productivity.

Features

Large icon based function keys allow you to modify honing data on the fly and access in-process features.

In process monitors allows you to determine machine status at a glance from motor torques to cycle-time monitors.

Programs can be stored for later recall facilitating minimum set up time for repeat work.

Parameters are entered in a logical order and all pages accompanied by clear graphics to highlight the effect of each parameter.

The lower panel contains primary functions such as cycle time, mode select & emergency stop buttons.

All this is facilitated by a Seimens touchscreen panel that can be maneuvered to suit the operator.



sales@delapena.co.uk

0044 1242 516341